

ADVANCE ADAPTERS INC.

P.O. Box 247, 4320 Aerotech Center Way

Paso Robles, CA 93447

Telephone: (800) 350-2223 Fax: (805) 238-4201

P/N: 712527

PAGE 1 OF 2

Page Rev. Date: 10-20-10

JEEP T150 3 SPEED TRANSMISSION 1976-79 TO CHEVY & BUICK ENGINES

KIT CONSISTS OF:

No.	Qty	Part No.	Description
1.	1	711527	ADAPTER PLATE
2.	1	716046	BEARING RETAINER
3.	1	716148	EXTENDED PILOT BUSHING (.670" I.D.)
4.	1	716731	SEAL (National #481792)
5.	4	723137	S.H.C.S. 5/16"-18x1" LONG
6.	2	725013	S.H.C.S. 1/2"-13x2" LONG
7.	1	725016	S.H.C.S. 1/2"-13x1-1/4" LONG
8.	2	725026	F.H.C.S. 1/2"-13x1-1/4" LONG
9.	1	JP001	JEEP INSTRUCTION MANUAL

INSTALLATION INSTRUCTIONS:

The Jeep input shaft has a clutch spline of 1-1/16"-10 which is common to all Ford products. When using a Chevy engine, a Ford clutch disc, Centerforce No. 381021 or 281226 must be used. **DO NOT ATTEMPT TO USE THE ORIGINAL JEEP CLUTCH DISC.** A special pilot bearing has been included with your kit and you must make sure that the tip of the transmission shaft properly engages into the new pilot bearing. There are certain installations that will require the tip of the shaft to be shortened in order to prevent the shaft from bottoming out into the engine crank. Make sure the splines on the input shaft engage with the clutch disc splines. Some clutch discs do not have the necessary offset to make proper engagement.

1. Install seal in adapter plate with the open side towards the transmission.
2. Bolt the new bearing retainer to the front of the adapter plate.
3. Bolt the adapter plate and retainer to the new Chevy bellhousing making sure that the retainer indexes properly into the bellhousing bore.
4. Using the flat head socket cap screws, bolt the plate to the bellhousing. After the bolts have been secured, it may be necessary to mark the flat head portion of the bolt for grinding and providing clearance for bolts that overlap.
5. The top two holes on the transmission will need to be elongated to match the adapter plate. The holes must be large enough for use with 1/2" bolts.
6. Apply RTV silicone between the transmission and adapter plate, this will prevent oil seepage.
7. Bolt the transmission to the adapter plate using the original Jeep bolts.
8. The following parts will be necessary:

Clutch release bearing

Clutch release lever

Pressure plate

11" clutch disc with 1-1/16"-10 spline (#281226)

Flywheel

Bellhousing with small index diameter of 4.686"

SPECIAL NOTE: The components packaged in this kit have been assembled and machined for specific type of conversions. Modifications to any of the components will void any possible warranty or return privileges. If you do not fully understand modifications or changes that will be required to complete your conversion, we strongly recommend that you contact our sales department for more information. This instruction sheet is only to be used for the assembly of Advance Adapter components. We recommend that a service manual pertaining to your vehicle be obtained for specific torque values, wiring diagrams and other related equipment. These manuals are normally available at automotive dealerships and parts stores.

ADVANCE ADAPTERS INC.

P.O. Box 247, 4320 Aerotech Center Way

Paso Robles, CA 93447

Telephone: (800) 350-2223 Fax: (805) 238-4201

P/N: 712527

PAGE 2 OF 2

Page Rev. Date: 05-01-95

JEEP T150 3 SPEED TRANSMISSION 1976-79 TO CHEVY & BUICK ENGINES

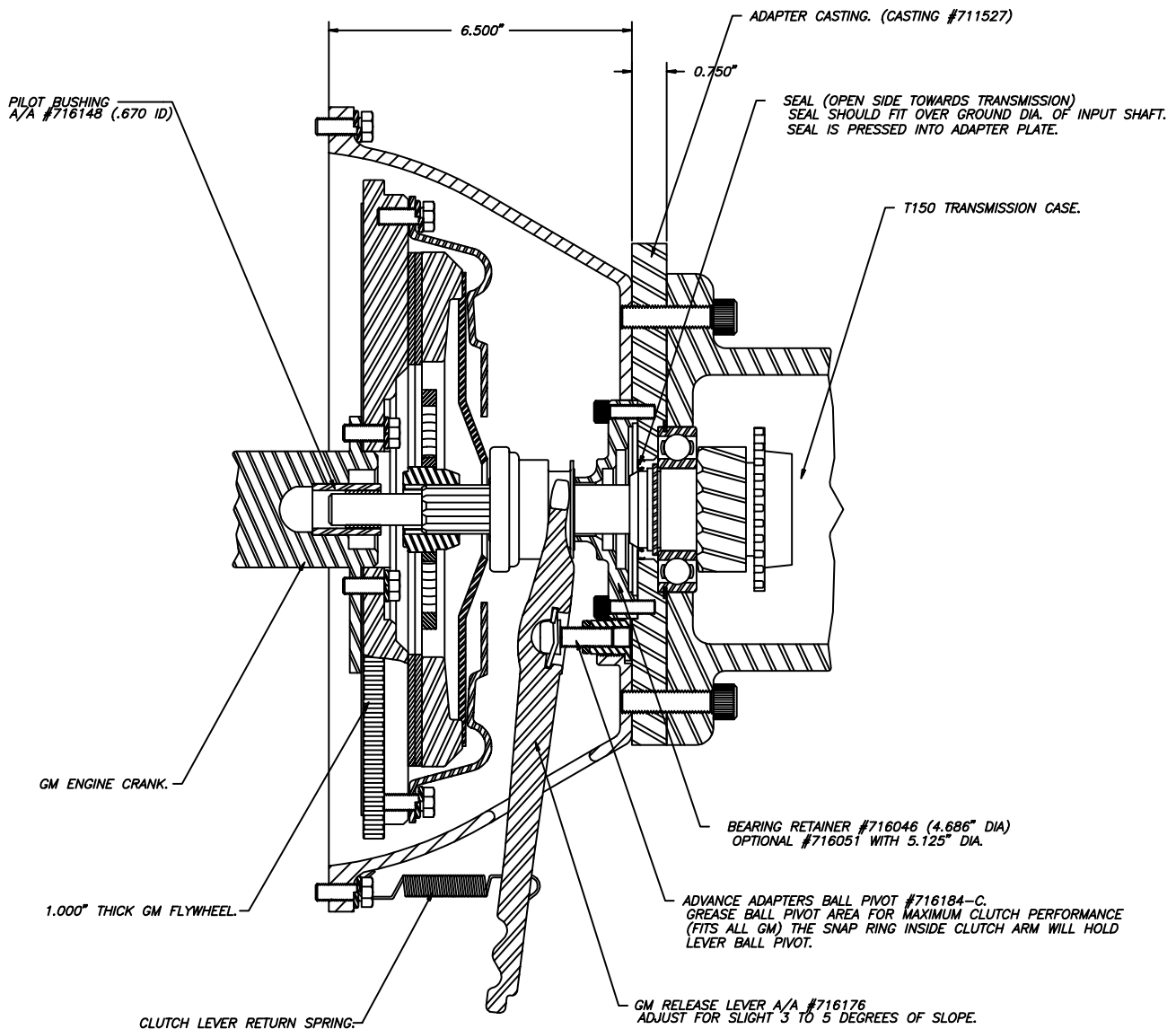

SPECIAL NOTE: The components packaged in this kit have been assembled and machined for specific type of conversions. Modifications to any of the components will void any possible warranty or return privileges. If you do not fully understand modifications or changes that will be required to complete your conversion, we strongly recommend that you contact our sales department for more information. This instruction sheet is only to be used for the assembly of Advance Adapter components. We recommend that a service manual pertaining to your vehicle be obtained for specific torque values, wiring diagrams and other related equipment. These manuals are normally available at automotive dealerships and parts stores.